



## COMMERCIAL DOOR OPERATOR

Maximum Door Area (Sq. Ft.)

HORSEPOWER	ROLLING		SECTIONAL		SECTIONAL	
	24 GA. STEEL ALUMINUM DOORS	22 GA. STEEL ALUMINUM DOORS	20 GA. STEEL STEEL GRILLES	24 GA./22 GA. STEEL ALUMINUM DOORS	20 GA. STEEL WOOD DOORS	16 GA. STEEL
1/3	310	285	260	210	175	125
1/2	400	350	320	280	250	200
3/4	560	500	450	380	325	275
1	640	625	560	475	400	310

NOTE: On steel insulated doors, a 24-gauge back panel is assumed. If a heavier back panel is supplied, use the next higher HP rating. Recommended Duty Cycles: 25 per hour, 80-90 per day

### Standard Features

- Motor**  
 Continuous-duty high-starting torque motor with instant reverse and overload protection. Available in 1/3, 1/2, 3/4 and 1 HP; single- or three-phase. Capacitor start on single-phase. Removable without affecting limit switch settings.
- Emergency Manual Operation**  
 Model H provides easy emergency manual operation using an electrically interlocked floor level disconnect and chain hoist mechanism.
- Wiring Type**  
 All operators are factory preset to C2 wiring, providing momentary contact to open and stop, with constant contact to close. Monitored entrapment protection, using approved photo sensors or sensing edges is optional, although recommended, when using C2, D1 or E2. All other wiring types, B2, T, TS and FSTS, can be selected with the addition of an appropriate monitored entrapment protection device, either LiftMaster CPS-U / CPS-UN4 photo sensors or a monitored 4-wire sensing edge (via a CPS-EI Edge Interface Card). Logic 4.0 operators can only accept UL-approved LiftMaster CPS-U, CPS-UN4 or CPS-EI monitored entrapment protection devices.
- Control Circuit**  
 5V DC NEC Class 2.
- Drive Reduction**  
 First-stage heavy-duty 5L V-belt; second and third stages #48 chain; #50 drive chain.
- PosiLock® Mechanical Brake System**  
 Self-locking mechanical reduction system functions as a holding brake.
- Bearings**  
 Industrial ball bearings on a 1" output shaft; heavy-duty, oil-filled iron bearings on reduction shafts.
- Friction Clutch**  
 Adjustable friction clutch helps protect against major damage to door and operator should the door meet an obstruction.
- Push Button Station**  
 3-button station for open/close/stop functions is standard for all operators. Controls with 1, 2 and 3 buttons are available.
- Radio Receiver & External Radio Control Terminal**  
 315MHz radio receiver included as standard on Logic 3.0. Accepts up to 23 Security+® remote controls or unlimited DIP switch remotes. External terminals provide quick, convenient connections for retrofitting or adding an external radio receiver.
- Construction**  
 NEMA 1 type electrical box, heavy-duty 11-gauge steel frame with durable powdercoat finish, all reduction sprockets drilled and pinned to shafts.

### Value Added Standard Features

- Timer-to-Close**  
 Automatically closes the door - programmable in 1-second or 15-second increments.
- Maximum Run Timer**  
 Signals door to reverse or stop if closing time exceeds maximum by more than 10 seconds.

# LiftMaster®

## Commercial Door Operators

THE CHAMBERLAIN GROUP, INC.

845 Larch Avenue • Elmhurst, IL 60126

www.liftmaster.com • http://specs.liftmaster.com/architectscorner

- Mid-Stop**  
 Stops door at programmable mid-stop during open travel.
- Delay-on-Reverse Circuit**  
 A 1.5 second delay-on-reverse circuit to prevent premature door and operator wear.

### Control Accessories and Options

- CPS® Commercial Protector System®**  
 LiftMaster photo sensors, CPS-U and CPS-UN4, are considered primary entrapment protection devices and are designed to sense an obstruction and instruct the operator to reverse a closing door to the full open position; LiftMaster photo sensors must be present in order to program any features or wiring types other than constant contact to close (C2, D1 and E2). In lieu of photo-sensors, the CPS-EI Edge Interface, which permits the attachment of a 4-wire monitored sensing edge to a Logic 4.0 operator, may be substituted as a primary entrapment protection device. CPS devices:
  - Signal the operator continuously in compliance with regulatory agency requirements regarding primary monitored entrapment protection devices
  - Provide LED indicators for quick and easy alignment
  - Feature heavy gauge mounting brackets and a bright, yellow safety color
  - Offer quick installation via pre-molded 1" conduit connections
  - Provide a watertight NEMA4 design (CPS-UN4)
- Sensing Edge**  
 If CPS-U / CPS-UN4 photo sensors are present, a non-monitored 2-wire electric edge or pneumatic (air hose) edge may be used as ancillary protection devices. For C2 mode only, installation of either a 2-wire electric or pneumatic edge is optional.
- Brake**  
 Heavy-duty solenoid-actuated brake.
- Transmitters**  
 1- and 3-button transmitters available. 3-button transmitter can be programmed for open/close/stop functionality.
- Rolling Door Interlock Switch**  
 Interlock switch disables the operator control circuit when a manual door lock is engaged, preventing damage to the door and operator.

### Available Plug-in Options for the Logic 4.0 Control Board (L4)

- TLS1CARD**  
 The Timer Light Status Card (TLS1CARD) provides the capability to control auxiliary devices such as warning lights, bells, horns, horn/strobes, etc. through timed relay activation occurring at various door positions (open, mid-stop or closed). The TLS1CARD also provides an input for external limit switches on tall rolling doors.
- AUXCARD**  
 Activates security, warning, heating or other 5V to 240V devices while door is in motion (either opening or closing).
- CPS3 & CPS3-N4**  
 Provides the ability to add a second set of photo sensors for additional safety. CPS3 includes CPS3CARD and a set of CPS-U photo sensors. CPS3-N4 includes the CPS3CARD and a set of CPS-UN4 photo sensors. CPS3CARD may be purchased separately.

### Technical Information

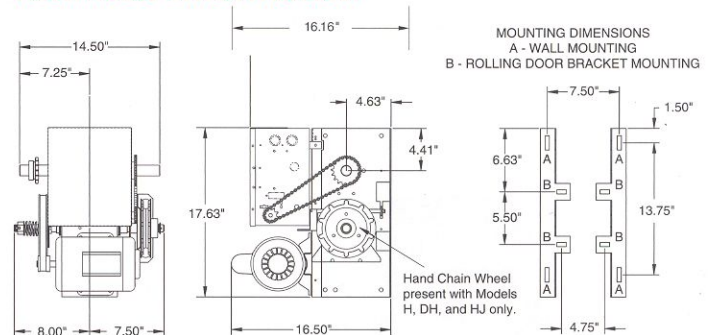

CHAMBERLAIN IS AN ISO9001:2008 REGISTERED COMPANY



Chamberlain reserves the right to make design or specification changes without notice.  
 ©2010 The Chamberlain Group, Inc. Printed in U.S.A. 08/10 LMCDCAO00H